

## 7 speed sequential manual smg transmission w drivelogic

---

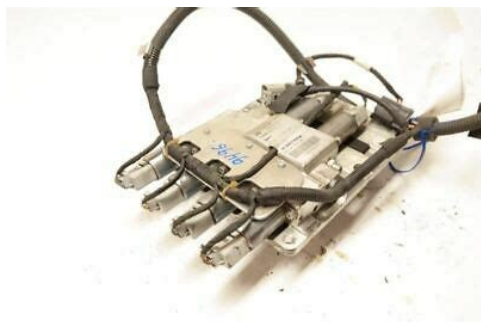

**File Name:** 7 speed sequential manual smg transmission w drivelogic.pdf

**Size:** 3327 KB

**Type:** PDF, ePub, eBook

**Category:** Book

**Uploaded:** 30 May 2019, 17:36 PM

**Rating:** 4.6/5 from 780 votes.

**Status:** AVAILABLE

Last checked: 11 Minutes ago!

**In order to read or download 7 speed sequential manual smg transmission w drivelogic ebook, you need to create a FREE account.**

[\*\*Download Now!\*\*](#)

eBook includes PDF, ePub and Kindle version

[Register a free 1 month Trial Account.](#)

[Download as many books as you like \(Personal use\)](#)

[Cancel the membership at any time if not satisfied.](#)

[Join Over 80000 Happy Readers](#)

### Book Descriptions:

We have made it easy for you to find a PDF Ebooks without any digging. And by having access to our ebooks online or by storing it on your computer, you have convenient answers with 7 speed sequential manual smg transmission w drivelogic . To get started finding 7 speed sequential manual smg transmission w drivelogic , you are right to find our website which has a comprehensive collection of manuals listed.

Our library is the biggest of these that have literally hundreds of thousands of different products represented.



## Book Descriptions:

### 7 speed sequential manual smg transmission w drivelogic



The highrevving concept only succeeds in combination with a gearbox which translates the torque available to the engine, by means of a short overall transmission ratio, into optimised forward thrust. The sevenspeed SMG gearbox is precisely the right transmission to ideally convey the V10 engines power via the drive train to the wheels. BMW M is the first manufacturer worldwide to offer a sevenspeed sequential gearbox with drivelogic function. Even more highly perfected than the previous sixspeed transmission, the sevenspeed SMG gearbox enables manual gear selection with ultrashort shifting times as well as comfortable cruising thanks to automated gear selection. The purpose of the additional seventh gear is to reduce engine speed and torque gaps. New SMG gearboxes speed up by 20 percent. With the sevenspeed SMG gearbox, gears can be changed using the gearshift lever on the centre console or the paddles on the steering wheel. Compared to the previous SMG transmission, changing gears is 20 percent faster with the new SMG generation. Never before has it been quicker to change gears with a transmission of this kind. The advantage for the M5 driver Gear change is smooth and accomplished at a speed impossible to reach even by the most proficient driver, thus making the inevitable power flow interruptions when changing gears hardly noticeable. The M5 delivers an almost jerkfree performance when accelerating from a standstill to its top speed. Drivelogic the driver determines the SMGs characteristics for changing gears Thanks to the SMGs drivelogic function, the driver can choose from eleven gear change options, which enable him to adapt the SMGs characteristics to his very own style of motoring. Six of these programs can be preselected in the sequential manual gearbox mode S mode, the spectrum ranging from balanced dynamic to very sporty. With the gearbox in the S mode, the driver always shifts gears manually. <http://www.smadie.fr/elements-of-x-ray-diffraction-solution-manual.xml>

- **7 speed sequential manual smg transmission w drivelogic.**

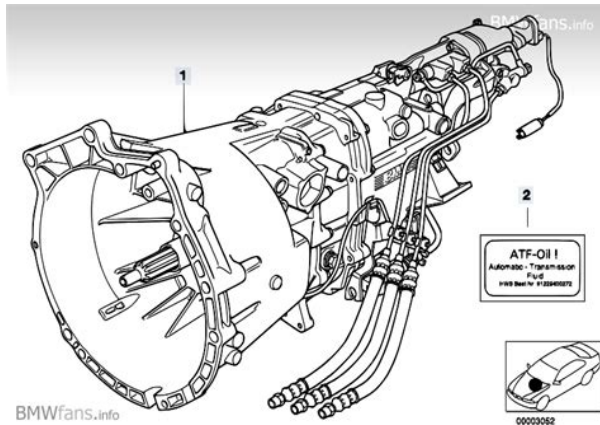

Whenever the driver activates the Launch Control function, the SMG Drivelogic shifts gears shortly before the maximum engine speed is reached at precisely the right moment and with optimum slip until the M5 reaches its top speed. In the Drive D mode automatic gearshift mode, the transmission shifts the seven gears automatically, depending on the program selected, the driving situation, the road speed and the position of the accelerator pedal. SMG for increased safety and comfort. The sevenspeed SMG gearbox not only supports the driver in achieving motor sports performance, but also offers scores of safety features. In critical situations, when the driver shifts down on a slippery surface, for example, the gearbox opens the clutch in the fraction of a second in order to prevent the M5 from swerving out of control in the event of excessive drag torque at the driven wheels. Further functions are the climbing, which prevents the car from rolling backwards during hill starts as well as the hill detection, which adjusts the shift points on gradients and descents. This prevents gear hunting when going uphill. When driving downhill, the hill detection holds the lower gears for longer in order to make effective use of the engines braking power. Maximum driving pleasure. The interaction of the V10 engine and the sevenspeed SMG gearbox results in a level of performance, which has so far been inconceivable for seriesproduction saloons. Above all, there is one thing the M5 gives to its driver driving pleasure at its best. The Nurburgring serves as a test track. Compared to all direct competitors, the interaction of actual forward thrust and a low vehicle weight is a strong argument in favour of the new M5. Also in this respect, the M5 sets the benchmark and leaves its competitors far behind. An undisputed gauge of driving dynamics is the northern loop of the legendary Nurburgring race

track. <http://bk21pluselec.com/userData/board/elenberg-cd-110mp3-service-manual.xml>



For decades, the worlds most demanding race track has been the perfect place of separating the wheat from the chaff. There is no other place where the interaction of vehicle components when taken to the limits can be observed as well as on the Nurburgrings northern loop. With lap times of approximately eight minutes, the M5 can hold its own and is a worthy competitor of thoroughbred

sports cars, leaving its competitors far behind. By the way traditionally, all M vehicles are tested there. Number of cars 866 Number of series 43 Number of engines 214 Latest cars AC Schnitzer. Cabrio. Innovations. M Series Spyshots. Touring. During the 2010s, AMTs were largely replaced by the increasingly widespread dualclutch transmission design. Torque and power transfer to the drive wheels will also be electronically controlled. Most modern implementations of this transmission function in a sequential mode, where the driver can only upshift or downshift by one gear at a time. However, this is not the case for all modern transmissions. Older transmissions usually from the 1990s and prior will retain H-pattern shifters, plus the shift gate, and will require the driver to select the required gear ratios manually. An early example of this transmission was introduced with the Hudson Commodore in 1942, called DriveMaster. This semiautomatic transmission used an automated clutch, which was actuated using hydraulics. Gear selection also used hydraulics, however, the gear ratio needs to be manually selected by the driver. This transmission, originally designed for trucks, was based on a manual transmission with the addition of hydraulic actuators for the gear shifter and the clutch. Initial versions did not allow direct selection of gear ratios, instead only allowing drivers to lock out higher gears as per many traditional automatic transmissions. Later versions added a manual mode, allowing the driver to control the gear selection.

Ferrari's involvement with automated manual transmission began with the 7-speed semiautomatic paddleshift transmission used in the 1989 Ferrari 640 Formula One racing car. The SMT system utilized an electrohydraulic activation system for both the clutch and shifting, but no H-pattern shifter like with the standard transmission. Instead, there was a shift lever that could be pulled and pushed forward or backward to upshift and downshift, as well as the addition of electronic steering wheel mounted shift buttons. Retrieved 12 June 2018. By using this site, you agree to the Terms of Use and Privacy Policy. SMG stands for Sequential Manual Gearbox. It's essentially a transmission capable of functioning as an automatic, or functioning as a manual transmission. The innovation is that, when functioning as an automatic, the driver does not need to operate a clutch pedal, simply designate desired gear. This is done by a traditional stick, or a set of paddle shifters attached to the steering column or steering wheel, depending on the model BMW. While automatic mode is more fuel efficient, manual mode provides greater engine performance while removing the human component and its capacity for error. This helps to ensure a longer life to the transmission and all its related parts. Structure The transmission design itself is not all that different from a normal automatic transmission. There's a number of planetary gear sets including a number of brakes and clutches, connected to valves, which are in turn connected to the body valve. The back of the planetary gear assembly is connected to the flywheel, with a clutch set in between the two to allow the power coming from the flywheel to be disengaged from the gear set at will. The other end of the planetary gear set is connected to a universal joint, which connects to a drive shaft. The drive shaft connects with the vehicle's drive axle to turn the wheels. How Does a BMW SMG Transmission Work.

<http://superbia.lgbt/flotaganis/1652967225>

When in automatic mode, the transmission functions normally. Power passes through the flywheel to the planetary gear sets. The gear sets spin in a certain configuration based on what clutches and brakes connected to them have engaged. The body valve controls these clutches and brakes based on the engines RPM, oil pressure, and other factors. When these factors raise beyond a certain threshold, the body valve changes the configuration of the brakes and clutches. This changes the configuration in which the planetary gears spin, altering the amount of power that's reaching the drive axle. This is how any automatic transmission normally shifts gears. When set in manual, the driver presses a button or operates the paddle that indicates a shift in gears is desired. This signal is interpreted by an onboard computer which overrides the body valve and forces the desired change in gears. References BMW SMG Transmissions About the Author This article was written by the It Still Works team, copy edited and fact checked through a multipoint auditing system, in efforts to ensure our readers only receive the best information. To submit your questions or ideas, or to simply learn more about It Still Works, contact us. More Articles What Is a CVT Transmission in a 2006. Transmission Overdrive Problems History of the A650E Transmission Parts That Make Up a Transmission What Is a Transmission Throttle Valve. What Is a DualLogic Transmission. How Does Traction Control Work on GM. What Is the Purpose of a Car. As with VW Group's DSG dualclutch gearbox, the M DCT promises to offer much smoother and faster shifts and at the same time reduced fuel consumption compared to a conventional system such as BMW's semiautomated SMG transmission. The driver can control the transmission by the selector lever or via paddles on the steering wheel.

<http://adams-tool.com/images/canon-eos-d30-manual-download.pdf>

Compared with all conventional systems available so far, this new gearbox ensures an optimum gearshift and even more dynamic acceleration, and at the same time reduces fuel consumption by a significant margin. In its gearshift characteristics, the new M doubleclutch transmission with Drivelogic is ideally matched to the fastrevving V8 power unit in the new BMW M3. Making its debut on the same occasion in the BMW M3 Coupe, the BMW M3 Saloon and the BMW M3 Convertible, the new transmission helps to provide even faster and more dynamic acceleration. Maintaining a permanent flow of power from the engine, reducing gear increments to a minimum and using dynamic torque surge when shifting gears, the M doubleclutch transmission with Drivelogic ensures a truly sporting experience at all times when shifting gears, whether in the automatic or manual mode. To activate the D or S mode and to shift to reverse, the driver first has the choice of the new sports shift lever exclusive to the BMW M3, enabling the driver to shift gears himself in the S mode. In this case he moves the gearshift lever only along one line, that is in a sequential process. In the years to come the Sequential M Gearbox SMG was consistently enhanced and upgraded in two further generations, optimised in its control logic and enhanced by the addition of further functions. Similar to the Sequential M Gearbox featured so far, the new gearbox fulfils all the specific requirements coming from motorsport in the transmission of supreme engine power to the drive wheels and offers unique control and gearshift technology all enhanced to an unprecedented standard. And like the three generations of the Sequential M Gearbox in the past, the M doubleclutch transmission with Drivelogic immediately comes at the top of the market in terms of sportiness and driving pleasure in a production car.

<https://gabrieliassociati.com/images/canon-eos-7d-manual.pdf>



On the race track, where every tenth of a second is crucial to winning or losing, this unique gearshift concept has proven its value and benefits in the same way as the sequential gearshift used in Formula 1. Shifting up with his foot fully on the throttle and without the slightest interruption of torque and pulling force makes even a professional driver a few fractions of a second faster, giving him that small but incredibly important advantage on the track. But now, for the first time, the benefits of a Double Clutch Gearbox are available for the first time even under supreme loads. The M doubleclutch transmission with Drivelogic is indeed the first power transmission of its kind the world over conceived and designed for engine speeds of up to 9,000 rpm. The “heart” of the new M doubleclutch transmission in technical terms is formed by the two oilcooled wet clutches. One of the two clutches is for the even 2, 4, 6, the other for the uneven 1, 3, 5, 7 gears and, in addition, for the reverse gear. When shifting gears, therefore, the first clutch opens just as the second clutch is closing. This ensures an absolutely smooth and comfortable and at the same time an incomparably fast gearshift without the slightest interruption in the flow of power. So if the BMW 3 Series is accelerating, say, in third gear, an immediate flow of power is ensured by the appropriate clutch and the gearbox component controlling the uneven gears. The only operation required for this purpose is to close the clutch for fourth gear, at the same time opening the clutch for third gear, the power of the engine then being transmitted through the new gear with its different ratio to the wheels. The additional power generated in this way comes out clearly in the new transmission ratio feeding torque and traction to the drive wheels.

The only difference is that the electronic transmission control makes the process of engaging the clutch smoother and softer to prevent the rear wheels from being slowed down suddenly and with too great an effect. This process of giving gas in between gears serves to further enhance the car’s driving stability and makes the entire driving experience even more intense. The drag force exerted by engine comes out only to the extent desired by the driver, remaining within the limits already well known from cars with a manual gearbox. So even with an extreme change in the style of motoring, the system changes gears appropriately, again at unparalleled speed and with unparalleled precision. Should the driver be required to suddenly stop the process of acceleration, for example, the M doubleclutch transmission will promptly provide the transmission ratio required under such new conditions, operating just as quickly and efficiently as a conventional automatic transmission of the latest generation set to an extremely dynamic gearshift mode. Dry sump lubrication, in turn, guarantees a high standard of reliability and maintenance-free function throughout the entire running life of the car. As an example, the transmission fluid is kept within the optimum temperature range not only by integrating the transmission into the coolant cycle of the engine. This again helps to reduce frictional losses in the warmup phase and saves fuel in the process. Quite simply, this is

because the particular power and performance characteristics of BMW's M Cars were taken into account from the start by the engineers in developing the new transmission. As a result, the M doubleclutch transmission is the first transmission of its kind able to handle engine speeds of up to 9,000 rpm. And at the same time it is perfectly prepared for high engine torque and extra power. Maximum torque, in turn, is 400 Newtonmetres or 295 lbft.

<https://www.lumisolar.pe/wp-content/plugins/formcraft/file-upload/server/content/files/16274e3e5c6300---brother-intellifax-4750e-manual-pdf.pdf>

As a result, the new gearbox shifts gears when accelerating with only a minimum gap or increment between the gears involved, ensuring an optimum flow of engine power and speed in every gearshift and allowing the driver to really enjoy the enormous power reserves of the engine. In practice, this means even faster and more dynamic acceleration clearly measurable in seconds and metres. The progress provided by this configuration comes to bear not only in the car's driving dynamics, but also in its driving comfort and efficiency. The fast and smooth shift of gears, for example, ensures an unusually harmonious process of acceleration. The load change reactions so typical of a conventional gearbox are avoided completely, ensuring a standard of driving comfort even under dynamic conditions never experienced before. This is primarily attributable to the even more direct connection between the engine and the M doubleclutch transmission as well as the general layout with seven gears. Quite simply, the advantage is that the larger number of gears allows even finer increments between the individual gear ratios. This again enables the driver to save fuel through an appropriate style of motoring, without making any concessions in terms of driving dynamics. For the M doubleclutch transmission is able to provide the appropriate gear for fast and powerful acceleration at any time and with incredibly fast operation, even in response to sudden command. In both cases gears are shifted at a rate and with a level of precision never seen before on a conventional manual gearbox or automatic transmission. At the same time the driver is able to enjoy the optimised gearshift comfort of the M doubleclutch transmission while switching over whenever he wishes to a more active and dynamic style of motoring. Then, via the appropriate paddle or with the help of the gearshift lever, the driver subsequently selects the gear of his choice.

For in both cases he is able to determine the degree of gearshift dynamics as he wishes. The configurations available range in several steps from a more balanced, comfort-oriented all the way to a very dynamic, racing-like setup of the transmission. Indeed, he is even able to save his personal favourite among the DriveLogic options as part of an individual, personalised configuration, then retrieving this specific function at any time simply by pressing the M Drive button on the multifunction steering wheel of his BMW M3. Then, just like the gear currently in mesh, the driving program selected is shown in the instrument cluster between the speedometer and the rev counter. Both of these parameters are varied in all driving programs as a function of current driving conditions, the speed of the car, and the position of the gas pedal. So choosing the appropriate driving program, the driver is able to use the sports and comfort potential of the M doubleclutch transmission as he wishes. In this case the clutch is particularly smooth and soft, helping the driver to set off without problems on, say, slippery surfaces in winter. Conversely, by kicking down the gas pedal he is able to quickly shift back to the best gear for optimum acceleration. In the most dynamic DriveLogic stages in the S mode, management of the clutch is very sporting and dynamic, creating the direct flow of power so typical of a car with a manual. Indeed, this kind of feedback to the driver after shifting gears serves to further emotionalise the driving experience in a BMW M3 with the M Double Clutch Gearbox. These Shift Lights enable the driver to precisely determine the ideal time for shifting gears. Six LED units flashing on in yellow one after the other accompany the engine as it approaches its top speed. The latest moment for shifting up is then presented by two LED units coming on in red.

A further point is that the driver is able to configure the individual operation of the Shift Lights via

the MDrive button and, if he wishes, deactivate their operation in the instrument cluster. Under optimum conditions in terms of the tyre condition, road surface and the load the car is carrying, Launch Control ensures the fastest possible acceleration from a standstill. To achieve this dynamic performance, all the driver has to do with the car at a standstill and in driving program S6 is move the sports shift lever to the front and hold it in this position. Then, as soon as the starter flag symbol comes on in the instrument cluster, the driver just presses down the gas pedal to automatically obtain the ideal starting speed on the engine. Pressing down the brake pedal lightly with his left foot, in turn, the driver can prevent the car from rolling forward, and by briefly tipping the cruise control lever he is able to finely adjust the desired starter speed. Then, after completing the acceleration process, the driver again takes command in choosing the gears he wishes to use. This serves to facilitate the gearshift process, reducing control forces in accordance with the dynamic character of the gearbox and the car itself. The shift commands determined by the driver through manual control are generated in a sequential process, that is on one single level. At the same time this highlights the close connection between the M doubleclutch transmission and motorsport technology. Made of solid aluminium, these paddles enable the driver to shift gears manually ultrafast and with maximum safety. In particular, this is because he does not have to take his hands off the steering wheel when shifting gears, which means extra safety in controlling the car. They therefore enhance not only the driving experience, but also the high standard of safety the driver enjoys at the wheel.

And at the same time the high quality finish of the aluminium paddles also establishes a direct link to motorsport with the flair of a genuine racing car. Pulling the paddle or tipping the gearshift lever only once therefore makes the transmission shift down either one or several gears, whatever is appropriate. The electronic control unit in command of the M doubleclutch transmission automatically changes the gear currently in mesh to give the car optimum acceleration under its current driving conditions and at the speed at which it is travelling. In critical driving situations, for example, the M doubleclutch transmission instantaneously opens the clutch currently active to prevent the rear end of the car from swerving round due to engine drag forces suddenly acting on the drive wheels. This function already well known from the automatic transmission serves to significantly increase driving and control comfort, for example when parking, and is activated by briefly tipping the gas pedal. After the engine has been switched off, the electronic control unit also automatically activates a parking lock acting through the transmission. Driving uphill, for example, this function avoids the constant change of gears so typical of a conventional automatic transmission, the so-called pendulum gearshift with the gears constantly shifting up and down. When driving downhill, on the other hand, the M doubleclutch transmission keeps the lower gears in mesh longer than would otherwise be the case in order to capitalise on the brake power of the engine. And last but not least, the choice of gears is automatically adjusted to an uphill gradient in the automated mode. The M doubleclutch transmission with Drivelogic excellently enhances the particularly dynamic character of this high performance sports car bearing the M logo.

In its M specific configuration, the new transmission harmonises perfectly with the engine and suspension technology of the BMW M3 based from the start on the particular features and requirements of motorsport. And at the same time the M doubleclutch transmission with Drivelogic makes a helpful contribution to driving comfort and supports the driver in ensuring maximum efficiency at the wheel. Compared with a conventional automatic transmission, for example, there is no loss of energy otherwise caused by the torque converter. In this way the M doubleclutch transmission with Drivelogic also helps to reduce fuel consumption and emissions. Hell, even an excellent automated system such as the Porsche PDK gets crapped all over by some of the purist purists. Well, I'd like to take this moment to clarify a few things about BMW's "awful" SMG II transmission featured in the E46 M3 that so many avoid like the plague. Advertisement The Affordable Supercar The Ultimate E46 M3 Buyers Guide A mostly complete guide on purchasing the Ultimate Driving Machine. Dont Panic. Read more First things first, I daily drive a three pedal BMW

and I love them as much as the next rowyourown purist. That said, I think it makes no sense to mandate that a traditional manual is the only way to go for all enthusiast cars. Advertisement What exactly is the SMG II. The SMG II Drivelogic is BMW's second generation of their Sequential Manual Gearbox offered in the E46 M3 and possibly some other models that don't come to mind at the moment. It's not a different transmission though. It's the same manual gearbox that, instead of having the clutch foot operated, has the clutch electrohydraulically operated via a pump and wired to computers. I want to say it's similar to Lamborghini's original EGear system, but I don't know enough about Lamborghini's system to say for sure please chime in if you know. Advertisement So if I dyno an SMG car, it would put down the same power Yes.

Is it as fast Independent testing suggests that in the most aggressive S6 setting, it shifts faster than even the fastest manual driver. However, real world comparisons tends to have SMG and manual cars neck and neck. So pretty much. Advertisement Does an SMG car weigh more. From what I was able to find, SMG cars weigh about 18 lbs more. So why does everyone hate it. Because when the system does have issues it's headache inducing and wallet draining. However, problems are always easier to understand when investigated and broken down as opposed to pointing in the general direction of an SMG and simply saying "all that is one big clusterfuck". The transmission itself usually holds up fine, it's the hydraulic pump, the solenoids, and the relays that fail and if you really want to get technical, the pumps tend to hold up fine, it's the motors within that fail. These items can get expensive. Advertisement And it's not nearly as involving as a manual right. That's all opinion. Would you think the 458 Italia and 991 GT3 are also cars that aren't involving. I drive both a manual car and an SMG car and I find the SMG car to be fun in very different way. Advertisement What's your point anyway. My point is that a manual E46 M3, assuming identical condition and option specs, is not worth many thousands over the SMG variant. However, I will attest that manuals should be valued higher. Any more than that seems like it would be too much of a premium. Advertisement Above all, my point is to consider these points before blindly defending the manual transmissions. I love manuals and I would drive them for the rest of my life, but they're not the end all be all of fun driving. Share This Story Get our newsletter Subscribe. We may earn money from the links on this page. BMW's sevenspeed, doubleclutch automated manual transmission is now available in the M3. This gearbox shifts quicker than is possible with a manual and also has a livable, smoothshifting automatic mode.

Since only one clutch is engaged at any given time, the transmission anticipates and preselects the next ratio; a gearchange simply requires one clutch to release while the other engages, which means the M DCT can shift quicker than a manual transmission, and it drastically reduces the power interruption between gears. Overall, first gear with M DCT is actually slightly taller than in the manual, but the rest of the ratios are shorter. If you've ever driven an SMG car, you know what we're talking about. Even with various iterations and improvements, the current sevenspeed unit found in the M5 and M6 leaves large, headbobbing gaps in power between shifts, rendering it somewhere between annoying and unusable in fullautomatic mode. A setting of four or higher means satisfying throttle blips accompany downshifts; settings one through three yield nearly imperceptible gearchanges. Manual shifting is accomplished via steeringwheelmounted paddles right for upshifts, left for downshifts or the shift lever on the center console. Omitted from U.S. versions of the M5 and M6, launch control is thankfully now included in the M3. You may be able to find more information about this and similar content at piano.io. Shop Subscribe Latest News Jalopnik Reviews The Morning Shift Nice Price Car Buying Video The Inventory Drive Free or Die. Latest News Jalopnik Reviews The Morning Shift Nice Price Car Buying Video The Inventory MPower. Drop your email here and get our stories in your inbox. Call it the M doubleclutch transmission with DriveLogic. The SMG system uses a highpressure hydraulic actuator to shift gears, with the latest version i.e., SMG II offering five automatic modes and six manual modes and shift times in around 80 miliseconds. An algorithm takes into account throttle position, engine speed, road speed and shift mode in use when

calculating shift management. What else do we know about the new M doubleclutch transmission with DriveLogic. Click through. Advertisement 1.

<http://gbb.global/blog/bose-powered-acoustimass-3-series-ii-manual>